

ENGINE LUBRICATION SYSTEM

CONTENTS

PRECAUTION	2	Inspection	7
PRECAUTIONS	2	Changing Engine Oil	8
Precaution for Supplemental Restraint System (SRS) "AIR BAG" and "SEAT BELT PRE-TENSIONER"	2	OIL FILTER	9
Precautions Necessary for Steering Wheel Rotation after Battery Disconnect	2	Removal and Installation	9
Precaution for Liquid Gasket	2	ON-VEHICLE REPAIR	10
PREPARATION	4	OIL PUMP	10
PREPARATION	4	Removal and Installation	10
Special Service Tool	4	Disassembly and Assembly	10
Commercial Service Tool	4	OIL COOLER	13
FUNCTION DIAGNOSIS	6	Removal and Installation	13
LUBRICATION SYSTEM	6	SERVICE DATA AND SPECIFICATIONS (SDS)	15
Lubrication Circuit	6	SERVICE DATA AND SPECIFICATIONS (SDS)	15
Schematic	6	Oil Pressure	15
ON-VEHICLE MAINTENANCE	7	Regulator Valve	15
ENGINE OIL	7	Oil Pump	15
		Oil Capacity	15

PRECAUTIONS

< PRECAUTION >

PRECAUTION

PRECAUTIONS

Precaution for Supplemental Restraint System (SRS) "AIR BAG" and "SEAT BELT PRE-TENSIONER"

INFOID:000000004173702

The Supplemental Restraint System such as "AIR BAG" and "SEAT BELT PRE-TENSIONER", used along with a front seat belt, helps to reduce the risk or severity of injury to the driver and front passenger for certain types of collision. This system includes seat belt switch inputs and dual stage front air bag modules. The SRS system uses the seat belt switches to determine the front air bag deployment, and may only deploy one front air bag, depending on the severity of a collision and whether the front occupants are belted or unbelted. Information necessary to service the system safely is included in the SR and SB section of this Service Manual.

WARNING:

- To avoid rendering the SRS inoperative, which could increase the risk of personal injury or death in the event of a collision which would result in air bag inflation, all maintenance must be performed by an authorized NISSAN/INFINITI dealer.
- Improper maintenance, including incorrect removal and installation of the SRS, can lead to personal injury caused by unintentional activation of the system. For removal of Spiral Cable and Air Bag Module, see the SR section.
- Do not use electrical test equipment on any circuit related to the SRS unless instructed to in this Service Manual. SRS wiring harnesses can be identified by yellow and/or orange harnesses or harness connectors.

Precautions Necessary for Steering Wheel Rotation after Battery Disconnect

INFOID:000000004394024

NOTE:

- Before removing and installing any control units, first turn the push-button ignition switch to the LOCK position, then disconnect both battery cables.
- After finishing work, confirm that all control unit connectors are connected properly, then re-connect both battery cables.
- Always use CONSULT-III to perform self-diagnosis as a part of each function inspection after finishing work. If a DTC is detected, perform trouble diagnosis according to self-diagnosis results.

This vehicle is equipped with a push-button ignition switch and a steering lock unit.

If the battery is disconnected or discharged, the steering wheel will lock and cannot be turned.

If turning the steering wheel is required with the battery disconnected or discharged, follow the procedure below before starting the repair operation.

OPERATION PROCEDURE

1. Connect both battery cables.

NOTE:

Supply power using jumper cables if battery is discharged.

2. Carry the Intelligent Key or insert it to the key slot and turn the push-button ignition switch to ACC position. (At this time, the steering lock will be released.)
3. Disconnect both battery cables. The steering lock will remain released with both battery cables disconnected and the steering wheel can be turned.
4. Perform the necessary repair operation.
5. When the repair work is completed, re-connect both battery cables. With the brake pedal released, turn the push-button ignition switch from ACC position to ON position, then to LOCK position. (The steering wheel will lock when the push-button ignition switch is turned to LOCK position.)
6. Perform self-diagnosis check of all control units using CONSULT-III.

Precaution for Liquid Gasket

INFOID:000000004173703

REMOVAL OF LIQUID GASKET SEALING

- After removing nuts and bolts, separate the mating surface using Tool and remove old liquid gasket sealing.

PRECAUTIONS

< PRECAUTION >

Tool number : KV10111100 (J-37228)

CAUTION:

Be careful not to damage the mating surfaces.

- Tap (1) Tool to insert it, and then slide it (2) by tapping on the side as shown.
- In areas where Tool is difficult to use, use plastic hammer to lightly tap the parts, to remove it.

CAUTION:

If for some unavoidable reason tool such as screwdriver is used, be careful not to damage the mating surfaces.

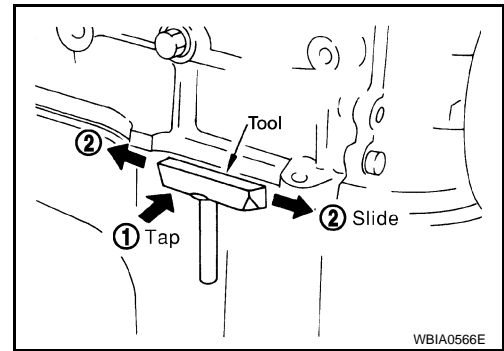

LIQUID GASKET APPLICATION PROCEDURE

1. Remove old liquid gasket adhering to the liquid gasket application surface and the mating surface, Using scraper.
 - Remove liquid gasket completely from the groove of the liquid gasket application surface, bolts, and bolt holes.
2. Thoroughly clean the mating surfaces and remove adhering moisture, grease and foreign materials.

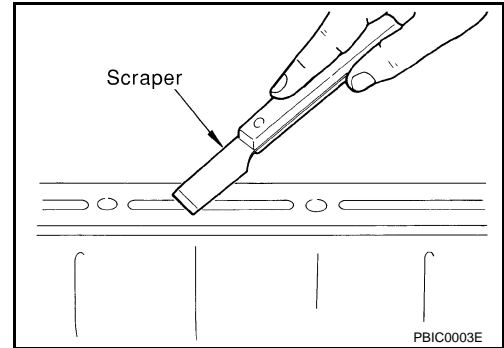

3. Attach liquid gasket tube to Tool.

Tool number : WS39930000 (—)

Use Genuine RTV Silicone Sealant or equivalent. Refer to [GI-15, "Recommended Chemical Products and Sealants"](#).

4. Apply liquid gasket without breaks to the specified location with the specified dimensions.
 - If there is a groove for the liquid gasket application, apply liquid gasket to the groove.

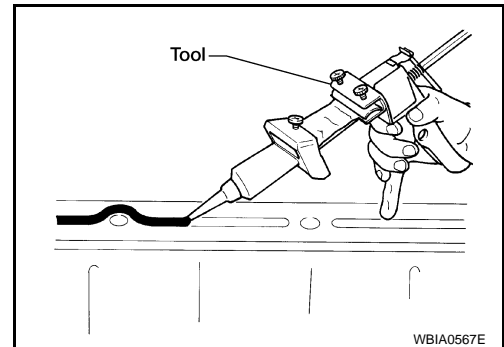

- As for the bolt holes, normally apply liquid gasket inside the holes. Occasionally, it should be applied outside the holes. Make sure to read the text of service manual.
- Within five minutes of liquid gasket application, install the mating component.
- If liquid gasket protrudes, wipe it off immediately.
- Do not retighten nuts or bolts after the installation.
- After 30 minutes or more have passed from the installation, fill engine oil and engine coolant.

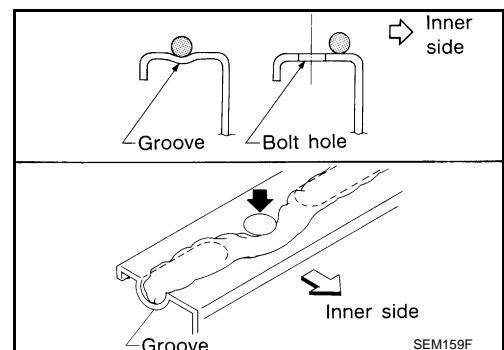

CAUTION:

If there are specific instructions in this manual, observe them.

A
LU
C
D
E
F
G
H
I
J
K
L
M
N
O
P

PREPARATION

< PREPARATION >

PREPARATION

PREPARATION

Special Service Tool

INFOID:000000004173704

The actual shapes of Kent-Moore tools may differ from those of special service tools illustrated here.

Tool number (Kent-Moore No.) Tool name	Description
ST25051001 (J-25695-1) Oil pressure gauge	Measuring oil pressure Maximum measuring range: 2,452 kPa (25 kg-cm², 356 psi)
ST25052000 (J-25695-2) Hose	Adapting oil pressure gauge to upper oil pan
KV10115801 (J-38956) Oil filter wrench	Removing and installing oil filter
KV10111100 (J-37228) Seal cutter	Removing steel oil pan and rear timing chain case
WS39930000 (—) Tube presser	Pressing the tube of liquid gasket

Commercial Service Tool

INFOID:000000004173705

PREPARATION

< PREPARATION >

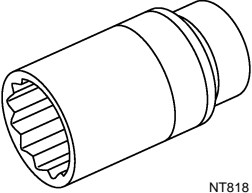
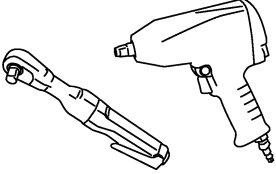
Tool name	Description
<p data-bbox="164 199 293 226">Deep socket</p>  <p data-bbox="850 415 896 432">NT818</p>	<p data-bbox="1013 199 1446 254">Removing and installing oil pressure switch Deep socket 26 mm, 3/8 drive</p>
<p data-bbox="164 451 285 478">Power tools</p>  <p data-bbox="850 667 922 684">PBIC0190E</p>	<p data-bbox="1013 451 1263 478">Loosening nuts and bolts</p>

A

LU

C

D

E

F

G

H

I

J

K

L

M

N

O

P

LUBRICATION SYSTEM

< FUNCTION DIAGNOSIS >

FUNCTION DIAGNOSIS

LUBRICATION SYSTEM

Lubrication Circuit

INFOID:000000004173706

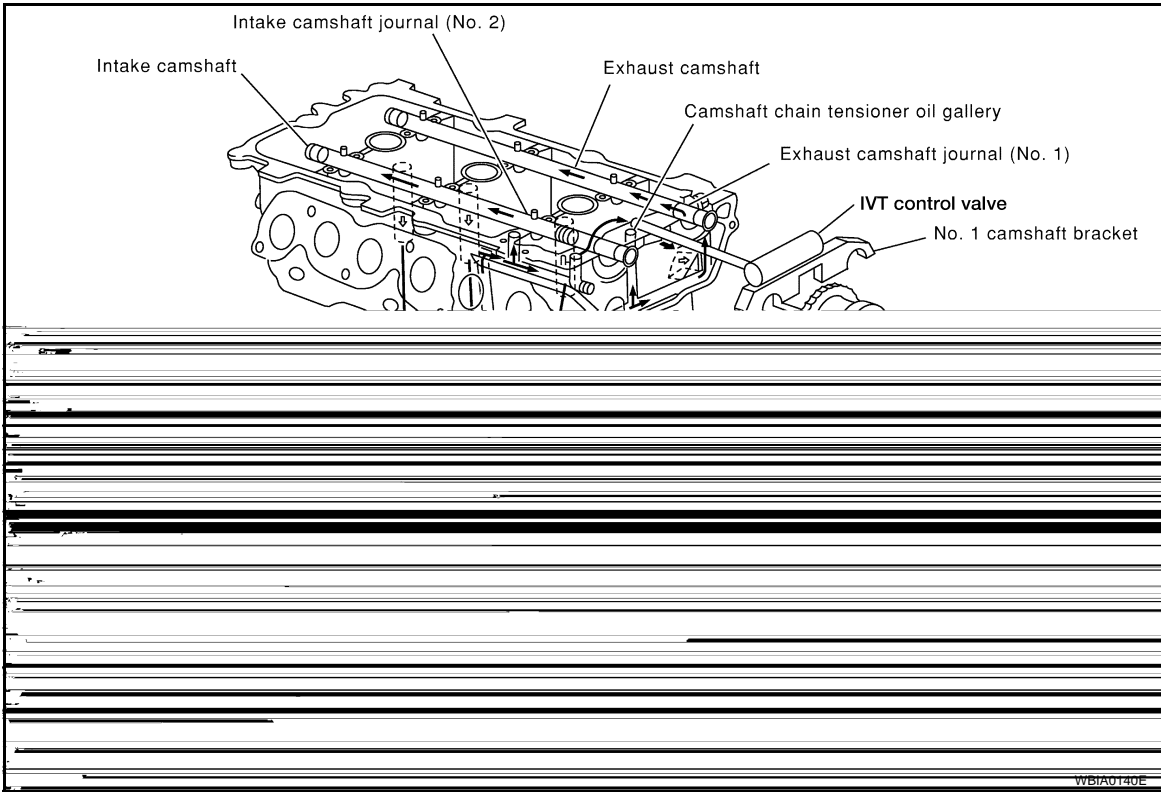

Schematic

INFOID:000000004173707

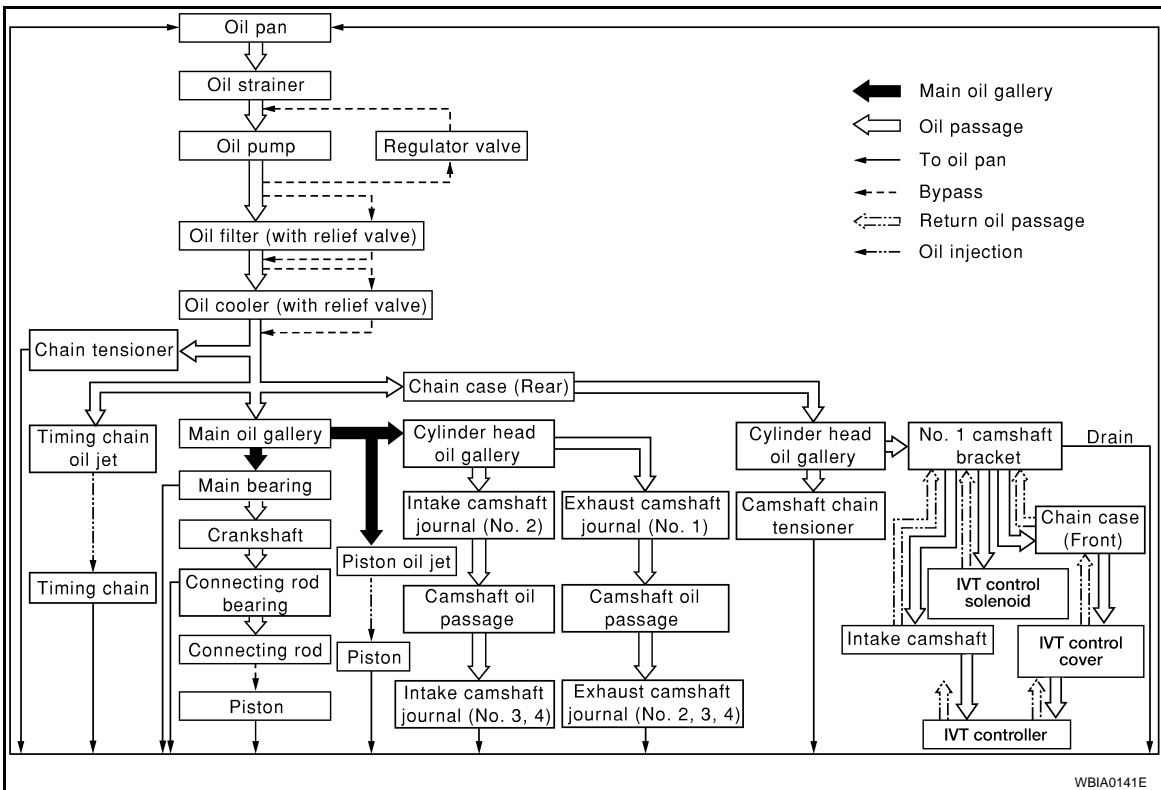

ENGINE OIL

< ON-VEHICLE MAINTENANCE >

ON-VEHICLE MAINTENANCE

ENGINE OIL

Inspection

INFOID:000000004173708

A

LU

OIL LEVEL

NOTE:

- Before starting the engine, check the oil level. If the engine is already started, stop it and allow 10 minutes before checking.
- Check that the oil level is within the range as indicated on the dipstick.
- If it is out of range, add oil as necessary. Refer to [LU-7, "Inspection"](#).

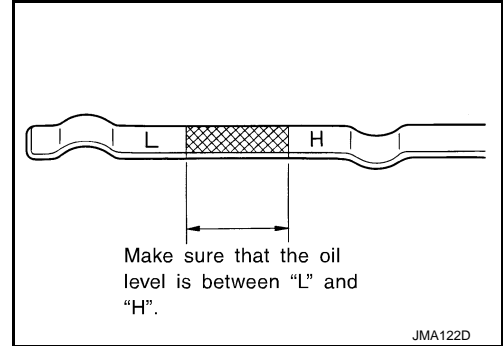

C

D

E

F

ENGINE OIL APPEARANCE

- Check engine oil for white milky appearance or excessive contamination.
- If engine oil becomes milky, it is highly probable that it is contaminated with engine coolant. Repair or replace damaged parts.

G

OIL LEAKAGE

Check for oil leakage around the following areas:

- Oil pan
- Oil pan drain plug
- Oil pressure switch
- Oil filter
- Oil cooler
- IVT cover
- Front cover
- Mating surface between cylinder block and cylinder head
- Mating surface between cylinder head and rocker cover
- Crank oil seal (front and rear)

H

I

J

OIL PRESSURE CHECK

WARNING:

- **Be careful not to burn yourself, as engine oil may be hot.**
 - **For M/T models, put the gearshift lever in the Neutral "N" position. For CVT models, put the selector lever in the Park "P" position.**
1. Check the oil level. Refer to [LU-7, "Inspection"](#).
 2. Remove undercover using power tool.
 3. Disconnect oil pressure switch harness connector at the oil pressure switch. Remove oil pressure switch and install Tools.

Tool numbers : ST25051001 (J-25695-1)
: ST25052000 (J-25695-2)

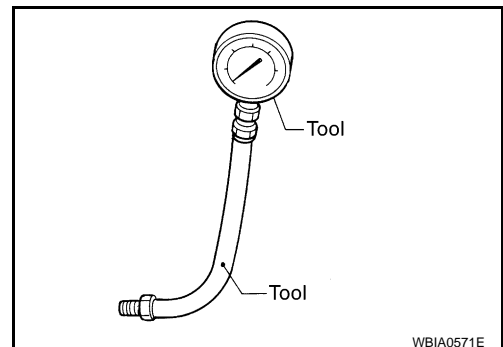

K

L

M

N

O

P

4. Start the engine and warm it up to normal operating temperature.
5. Check oil pressure with engine running under no-load, using Tool.
If difference is extreme, check oil passage and oil pump for oil leaks.

ENGINE OIL

< ON-VEHICLE MAINTENANCE >

6. After the inspections, install the oil pressure switch as follows:
 - a. Remove the old sealant adhering to oil pressure switch and engine.
 - b. Apply thread sealant and tighten the oil pressure switch to specification.
Use Genuine High Performance Thread Sealant, or equivalent. Refer to [GI-15, "Recommended Chemical Products and Sealants"](#).

Oil pressure switch : 14.7 N-m (1.5 kg-m, 11 ft-lb)

Changing Engine Oil

INFOID:000000004173709

WARNING:

- **Be careful not to burn yourself, as the engine oil may be hot.**
 - **Prolonged and repeated contact with used engine oil may cause skin cancer; try to avoid direct skin contact with used oil. If skin contact is made, wash thoroughly with soap or hand cleaner as soon as possible.**
1. Position the vehicle so it is level on the hoist.
 2. Warm up the engine and check for oil leaks from the engine.
 3. Stop engine and wait for 10 minutes.
 4. Remove the oil pan drain plug and oil filler cap.
 5. Drain the engine oil.
 6. Install the oil pan drain plug with a new washer and refill the engine with new engine oil.

Oil specification and viscosity : Refer to [MA-17, "FOR NORTH AMERICA : Engine Oil Recommendation"](#) or [MA-19, "FOR MEXICO : SAE Viscosity Number"](#).

Oil pan drain plug : Refer to [EM-33, "Removal and Installation"](#).

CAUTION:

- **Be sure to clean the oil pan drain plug and install with a new washer.**
 - **The refill capacity depends on the oil temperature and drain time. Use these specifications for reference only. Always use the dipstick to determine when the proper amount of oil is in the engine.**
7. Warm up the engine and check around the oil pan drain plug and oil filter for oil leaks.
 8. Stop engine and wait for 10 minutes.
 9. Check the engine oil level using the dipstick.

CAUTION:

Do not overfill the engine oil.

OIL FILTER

< ON-VEHICLE MAINTENANCE >

OIL FILTER

Removal and Installation

INFOID:000000004173710

REMOVAL

1. Remove engine undercover.
2. Remove the oil filter using Tool A as shown.

Tool number : KV10115801 (J-38956)

CAUTION:

- Be careful not to get burned; the engine oil may be hot.
- When removing, prepare a shop cloth to absorb any oil leakage or spillage.
- Do not allow engine oil to adhere to the drive belts.
- Completely wipe off any oil that adheres to the engine and the vehicle.

- The oil filter is provided with a relief valve. Use a genuine NISSAN oil filter or equivalent

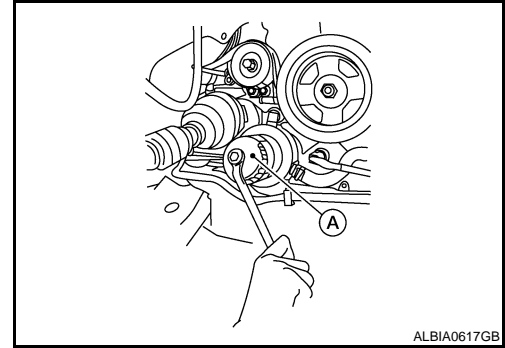

ALBIA0617GB

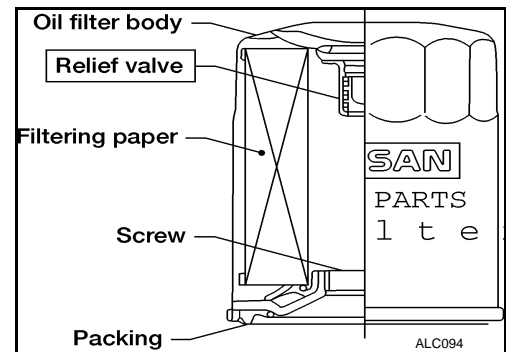

ALC094

INSTALLATION

1. Remove foreign materials adhering to the oil filter installation surface.
2. Apply clean engine oil to the oil seal contact surface of the new oil filter.

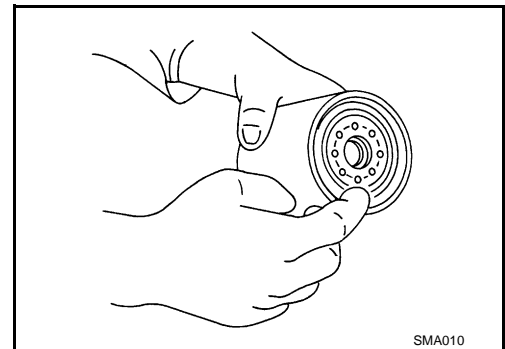

SMA010

3. Screw the oil filter manually until it touches the installation surface, then tighten it by turning another 2/3 turn, or tighten to specification.

Oil filter : 18.0 N·m (1.8 kg·m, 13 ft·lb)

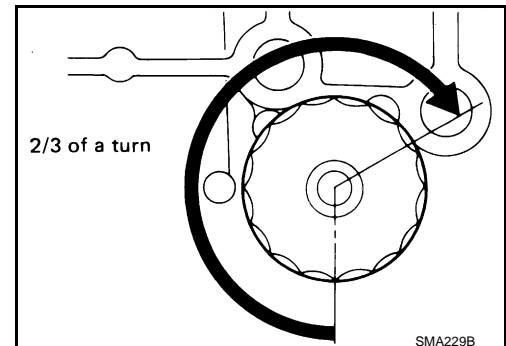

SMA229B

4. Check the oil level and add engine oil as necessary. Refer to [LU-7, "Inspection"](#).
5. After warming up the engine, check for any engine oil leaks.

OIL PUMP

< ON-VEHICLE REPAIR >

ON-VEHICLE REPAIR

OIL PUMP

Removal and Installation

INFOID:000000004173711

REMOVAL

1. Remove the timing chain. Refer to [EM-57. "Removal"](#).
2. Remove oil pump assembly.

INSTALLATION

Installation is in the reverse order of removal.

Disassembly and Assembly

INFOID:000000004173712

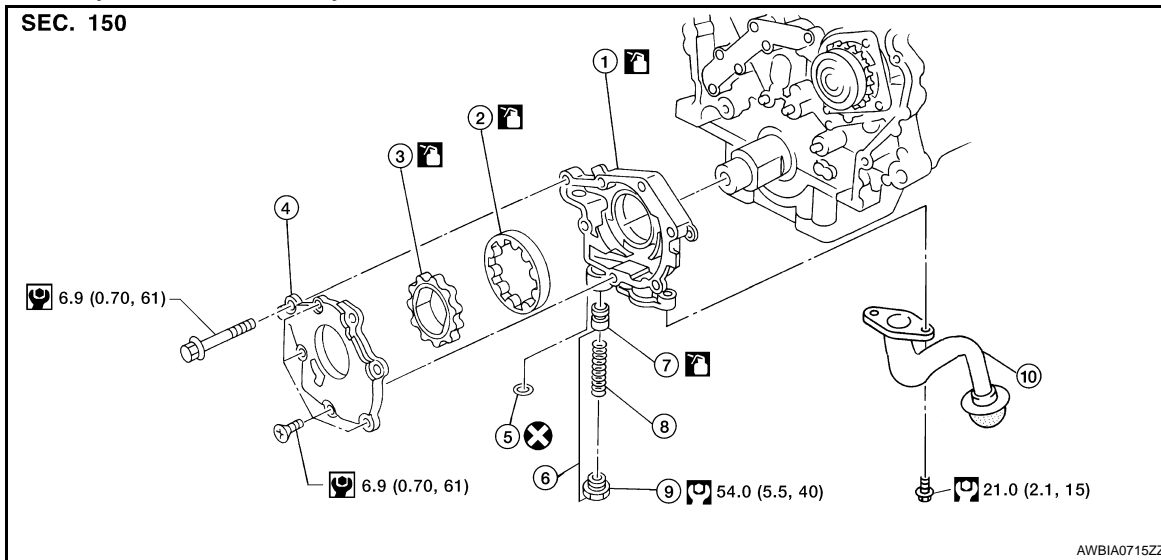

- | | | |
|---------------------|----------------|------------------------|
| 1. Oil pump housing | 2. Outer rotor | 3. Inner rotor |
| 4. Oil pump cover | 5. O-ring | 6. Regulator valve set |
| 7. Regulator valve | 8. Spring | 9. Regulator plug |
| 10. Oil strainer | | |

CAUTION:

Before assembly, apply new engine oil to the parts as shown.

DISASSEMBLY

1. Remove the oil pump cover.
2. Remove inner rotor and outer rotor from oil pump housing.
3. Remove oil strainer from oil pump housing.
4. After removing regulator plug, remove spring and regulator valve.

INSPECTION AFTER DISASSEMBLY

Clearance of Oil Pump Parts

OIL PUMP

< ON-VEHICLE REPAIR >

- Measure clearance with feeler gauge.
- Clearance between outer rotor and oil pump body (position 1).

Standard : 0.114 - 0.260 mm (0.0045 - 0.0102 in)

- Tip clearance between inner rotor and outer rotor (position 2).

Standard : Below 0.180 mm (0.0071 in)

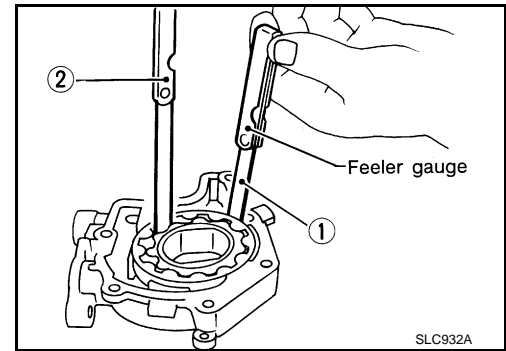

- Measure clearance with feeler gauge and straightedge.
- Side clearance between inner rotor and oil pump body (position 3).

Standard : 0.030 - 0.070 mm (0.0012 - 0.0028 in)

- Side clearance between outer rotor and oil pump body (position 4).

Standard : 0.050 - 0.110 mm (0.0020 - 0.0043 in)

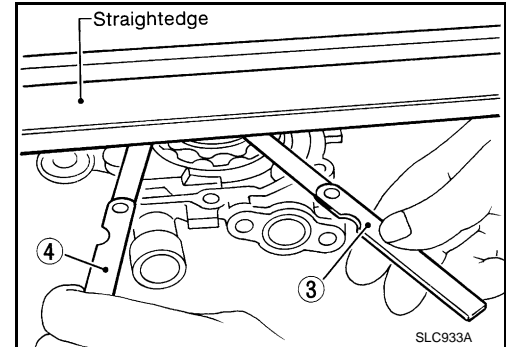

- Calculate the clearance between inner rotor and oil pump body as follows:

1. Measure the outer diameter of protruded portion of inner rotor (position A).
2. Measure the inner diameter of oil pump body with inside micrometer (position B).
(clearance 5) = (inner diameter of oil pump body B) – (outer diameter of inner rotor A)

Standard : 0.045 - 0.091 mm (0.0018 - 0.0036 in)

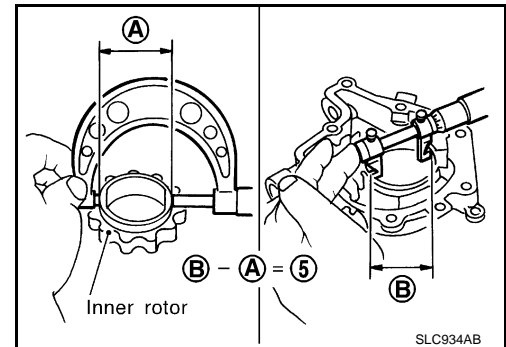

Regulator Valve

1. Visually inspect components for wear and damage.
2. Check oil pressure regulator valve sliding surface and valve spring.
3. Coat regulator valve with engine oil. Check that it falls smoothly into the valve hole by its own weight.

If damaged, replace regulator valve set or oil pump body.

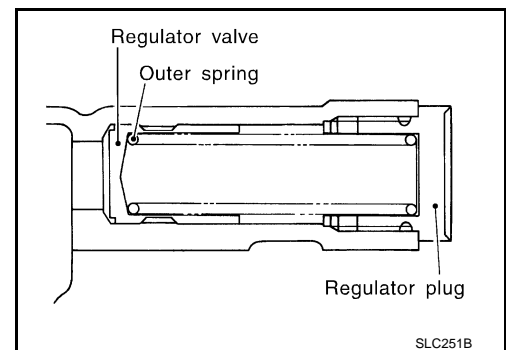

Regulator Valve Clearance

OIL PUMP

< ON-VEHICLE REPAIR >

(Clearance δ) = D (Valve hole diameter) – E (Outer diameter of valve)

Standard : 0.040 - 0.097 mm (0.0016 - 0.0038 in)

If it exceeds the standard, replace the oil pump body.

CAUTION:

Coat regulator valve with engine oil.

Check that it falls smoothly into the valve hole by its own weight.

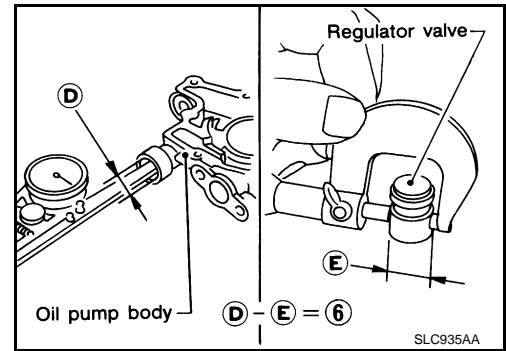

Assembly

Assembly is in the reverse order of disassembly.

- Assemble the inner rotor and outer rotor with the punched marks on the oil pump cover side.

CAUTION:

Before assembly apply new engine oil to the parts as specified.

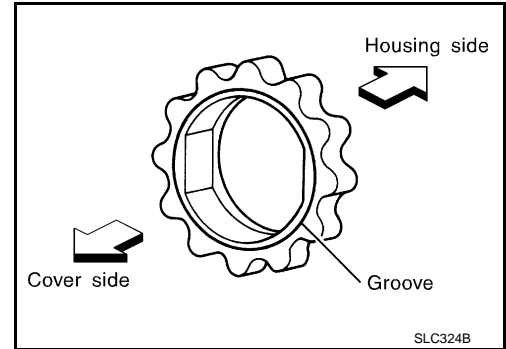

OIL COOLER

< ON-VEHICLE REPAIR >

OIL COOLER

Removal and Installation

INFOID:000000004173713

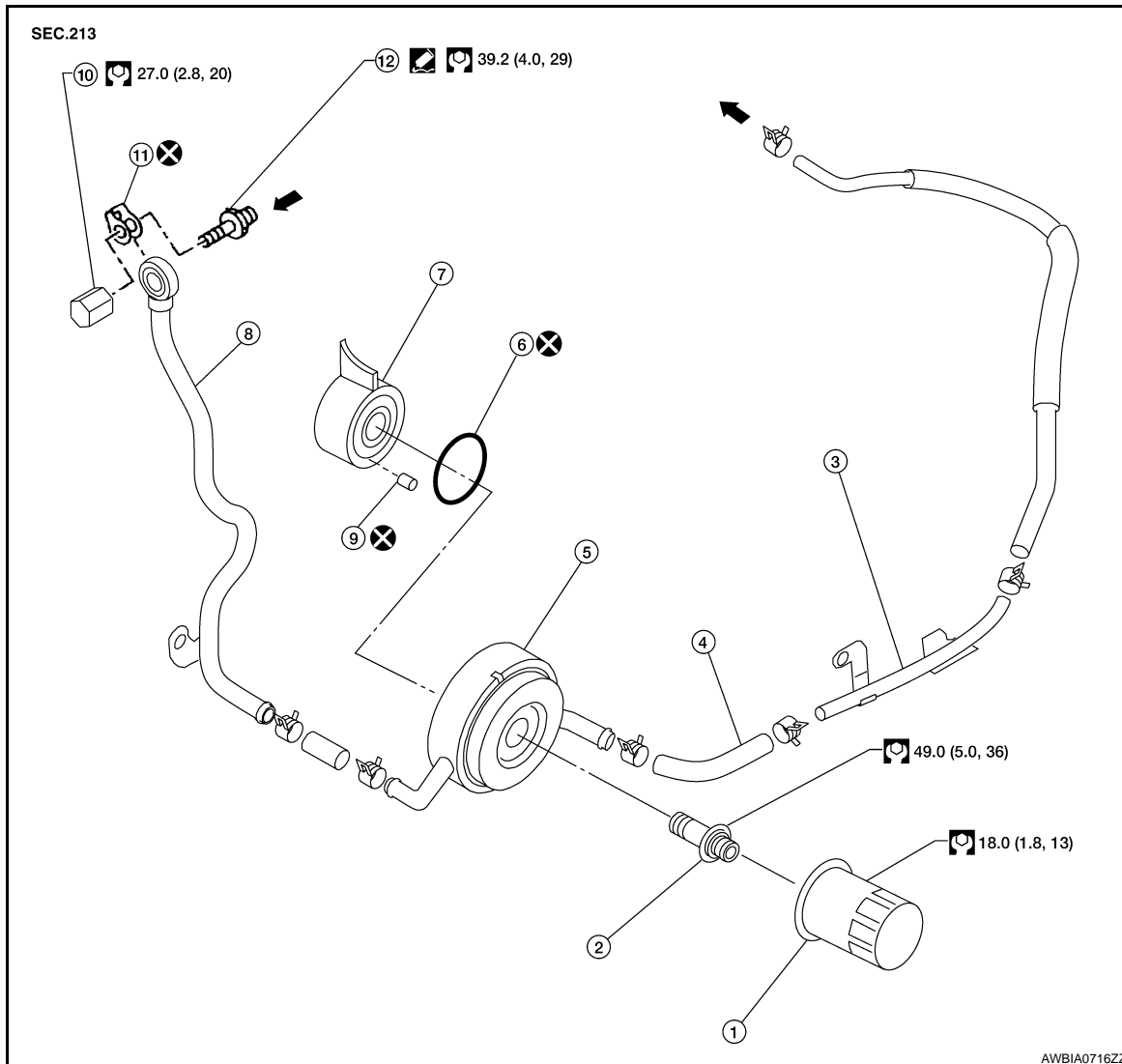

- | | | |
|----------------------|--------------------|---------------------|
| 1. Oil filter | 2. Oil cooler bolt | 3. Water pipe |
| 4. Water hose | 5. Oil cooler | 6. O-ring |
| 7. Oil pan | 8. Water pipe | 9. Relief valve |
| 10. Water drain plug | 11. Copper gasket | 12. Water connector |

← Coolant flow

REMOVAL

1. Drain engine oil. Refer to [LU-8, "Changing Engine Oil"](#).
2. Drain engine coolant. Refer to [CO-10, "Changing Engine Coolant"](#).
 - **Do not spill coolant on the drive belt.**
3. Disconnect water hoses from oil cooler.
4. Remove the oil filter. Refer to [LU-9, "Removal and Installation"](#).
5. Remove oil cooler.

INSPECTION AFTER REMOVAL

1. Check oil cooler for cracks.
2. Check oil cooler for clogging by blowing through coolant inlet. If necessary, replace oil cooler assembly.

Oil Pressure Relief Valve

OIL COOLER

< ON-VEHICLE REPAIR >

Inspect oil pressure relief valve for movement, cracks and breaks by pushing the ball. If replacement is necessary, remove valve by prying it out with a suitable tool. Install a new valve in place by tapping it.

INSTALLATION

Installation is in the reverse order of removal.

CAUTION:

When installing the oil cooler, align the oil cooler stopper with the stopper of the oil pan.

INSPECTION AFTER INSTALLATION

Start engine and check there are no leaks of engine oil or coolant.

SERVICE DATA AND SPECIFICATIONS (SDS)

< SERVICE DATA AND SPECIFICATIONS (SDS)

SERVICE DATA AND SPECIFICATIONS (SDS)

SERVICE DATA AND SPECIFICATIONS (SDS)

Oil Pressure

INFOID:0000000004173714

LU

Engine speed rpm	Approximate discharge pressure kPa (kg/cm ² , psi)
Idle speed	More than 98 (1.0, 14)
2,000	294 (3.0, 43)

Regulator Valve

INFOID:0000000004173715

Unit: mm (in)

Regulator valve to oil pump cover clearance	0.040 - 0.097 (0.0016 - 0.0038)
---	---------------------------------

Oil Pump

INFOID:0000000004173716

Unit: mm (in)

Body to outer rotor radial clearance	0.114 - 0.260 (0.0045 - 0.0102)
Inner rotor to outer rotor tip clearance	Below 0.180 (0.0071)
Body to inner rotor axial clearance	0.030 - 0.070 (0.0012 - 0.0028)
Body to outer rotor axial clearance	0.050 - 0.110 (0.0020 - 0.0043)
Inner rotor to brazed portion of housing clearance	0.045 - 0.091 (0.0018 - 0.0036)

Oil Capacity

INFOID:0000000004173717

Unit: ℓ (US qt, Imp qt)

Drain and refill	With oil filter change	Approximately 4.6 (4 7/8, 4)
	Without oil filter change	Approximately 4.3 (4 1/2, 3 3/4)
Dry engine (engine overhaul)		Approximately 5.0 (5 1/4, 4 3/8)